

Tracer Technology Provides Insight Into Leaking Trays And Entrainment

By Lowell Pless – Business Dev. Mgr – Distillation Applications
and Dave Ferguson – Business Dev. Mgr – Tracer Technology

Tracerco has completed many tracer projects worldwide that has enabled our customers to locate their particular process problem and provide critical information to assist with maintenance planning prior to shutdown.

While most of our readers are familiar with or have used our TRACERCO Diagnostics™ Leak study service for determining the presence of a leak in heat exchangers, they may not be aware of the successful track record tracers have had in determining leaks from draw trays in mass transfer towers and quantifying entrainment from spray headers. These on-stream leak tests are performed with the equipment operating at conditions giving rise to the problem. Some of the common effects encountered in a tower by our customers that would prompt them to contact Tracerco for assistance include:

- Light product found in bottoms material
- Unwanted heavy product found in light product

- Changes in temperature profiles
- Changes in product flows

TRU-SCANS® are recommended first to verify the mechanical integrity of the trays or packing. Results of the scans can rule out the possibility of mechanical damage or obvious process problems. An illustration of this can be found in Case Study 2. Once mechanical issues are ruled out, a leak small enough not to have an effect on hydraulics and hence be undetectable using a TRU-SCAN® may be present and can be determined using a TRACERCO Diagnostics™ Leak study. The following case study demonstrates how tracers were used to help locate a leak in a Wash Oil Tray and determine how much of the Wash Oil was being carried up to the HVGO draw.

Case Study 1: Leaking Wash Oil Tray

A Wash Bed tray was tested by injecting a specialist tracer into the Wash Oil feed that would not vaporize (Figure 1). The specialist tracer was selected based upon the very hot conditions encountered within the process and the instability and hence unsuitability of any organic based radio-tracer material. Detectors 1 and 2 were positioned on the Wash Oil line to measure the flow to the Wash Oil spray header. Detector 3 was on the Slop Wax



line, which is the draw from the Wash Bed tray, and was used to determine the amount of tracer that flowed from the Slop Wax draw tray. Detectors 4 and 5 on the HVGO draw line were used to confirm the flow from the HVGO draw tray. Detectors 6, 7, and 8 on the Vacuum Tower Bottoms (VTB) line were used for monitoring for the presence or absence of a leak.

Detector response results from the first injection are illustrated in Figure 2. The responses from detectors 6, 7 and 8 on the bottoms product line (tan, light blue and grey lines) indicated that a leak was detected. A slight increase in signal was noted from the bottoms outlet and VTB line detectors, while the detector with additional shielding did not show any slight increase. This indicated that the responses of the outlet and VTB line detectors were due to

(continued on page 2)

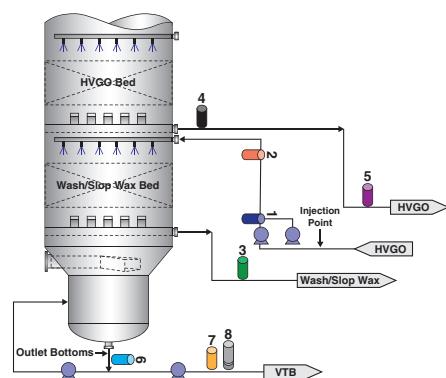

Figure 1 – Illustration of detector placement

INSIDE THIS ISSUE...

Tracer Technology Provides Insight Into Leaking Trays And Entrainment

1

TRU-SCAN® Field Testing and Process /Hydraulic Analysis Revealed Likely Causes of Flooding Problems

4

Leaking Trays

(Continued from page 1)

	Amount of tracer injected for calibration	Amount of tracer passing detectors during test	Ratio
HVGO Leak Test Area = HVGO Calibration Area =	12209 1874	1 mCi	6.5 mCi 41%
VTB Leak Test Area = VTB Calibration Area =	7797 1849	0.23 mCi	1.0 mCi 6%
Slop Wax Leak Test Area = Slop Wax Calibration Area =	88914 6443	0.62 mCi	8.6 mCi 53%
Amount of tracer injected for test = 16.0 mCi			

Table 1: Shows the calculated amount of tracer that passed through the HVGO, VTB and Slop Wax Lines.

tracer that leaked into the stream and not from tracer in an adjacent line or vessel. The data confirmed that approximately 6% of the Wash Oil feed was leaking into the Vacuum Tower bottom. Approximately 41% of the tracer was carried up through the HVGO draw tray and exited through the HVGO line. (Table 1)

In addition to the first injection, further injections were made into the Slop Wax, HVGO and Vacuum Tower Bottoms product lines to measure flow rates. Injecting a known amount of tracer material into each of these lines allowed the leak test data to be analyzed for total flow split providing the customer with accurate fractional flow into each line, as shown in Figure 3. Flow into the Wash Oil feed line was confirmed using detectors 1 and 2. The distance between the detectors was divided by the time between the centroids of the two tracer response peaks shown in Figure 3 to calculate the velocity of the fluid at line conditions. Conversions of fluid velocities

into volumetric flow of all 4 lines are shown in Table 2.

Conclusion

Confirmation of a leak and its size in the Slop Wax draw tray provided the customer the justification to plan the repair for the next shut-down. In addition, the measurement of the degree of entrainment led to ideas to improve performance of the vacuum column. The leak and entrainment study provided data that was unavailable by any other means.

Case Study 2: Saturates Gas Plant Absorber

The following Saturates Gas Absorber case study demonstrates how two complimentary Tracerco Diagnostics applications, TRU-SCAN® and the TRACERCO Diagnostics™ Leak Study service, can be used to provide a cost effective approach towards isolating a problem concerning unacceptable levels of water and off-spec product.

HVGO calibration flow at line conditions					
203	in	ft	1	ft ²	3.14
1.31	sec	12	in	4	5.615
bbl/86400 sec = 156,062 bbl day					
VTB calibration flow at line conditions					
108	in	ft	0.83	ft ²	3.14
2.58	sec	12	in	4	5.615
bbl/86400 sec = 29,276 bbl day					
Slop Wax calibration flow at line conditions					
56	in	ft	0.25	ft ²	3.14
0.67	sec	12	in	4	5.615
bbl/86400 sec = 5,261 bbl day					
Wash Oil test flow at line conditions					
294	in	ft	0.33	ft ²	3.14
1.03	sec	12	in	4	5.615
bbl/86400 sec = 31,940 bbl day					

Table 2: Shows volumetric flow from all four lines.

The gas absorber bottom product flows into the Debutanizer. Excessive water in the Debutanizer feed compromises its performance and can create corrosion problems in downstream equipment. There are several pathways for water to get into the Saturates Absorber bottom product. (Figure 5) These include:

- Water leaking from the total draw Tray 5
- Excessive water level on draw Tray 5, resulting in water overflowing the vapor risers
- High water level in the water settler, resulting in carryover from settler to Tray 1
- Reboiler leak introducing steam with hydrocarbon vapor below Tray 1

The first stage of the study was to carry out a TRU-SCAN® and neutron backscatter study of the column to verify the mechanical integrity of all the trays in the Absorber, paying particular attention to the liquid level on total draw Tray 5.

(continued on page 3)

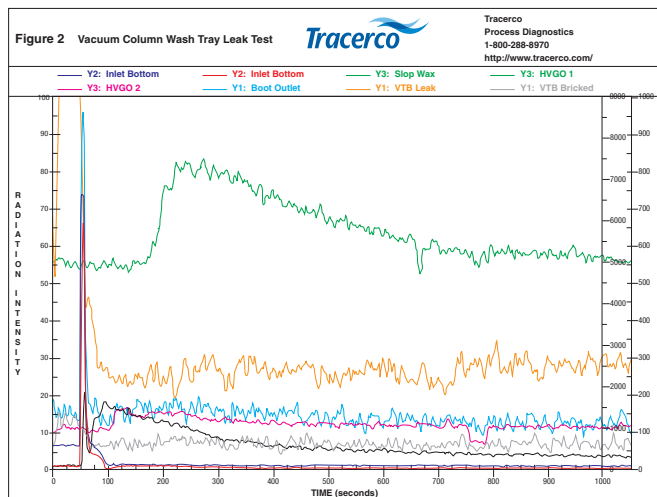

Figure 2 – Test results of the tan, light blue and grey line indicate a leak was found.

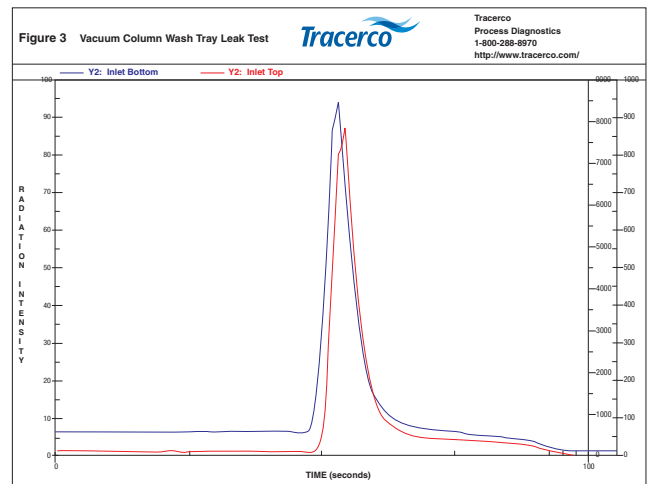

Figure 3 – Shows the responses of the two detectors on the Wash Oil line as the tracer entered the Vacuum column.

Leaking Trays

(Continued from page 2)

The TRU-SCAN® results (Figure 4) ruled out the possibility of significant mechanical damage or obvious process problems. In addition the results indicated that Tray 5 was holding 9 inches of liquid, well below the 14 inch vapor riser height.

A TruTec™ Neutron Backscatter was performed to determine the location of the

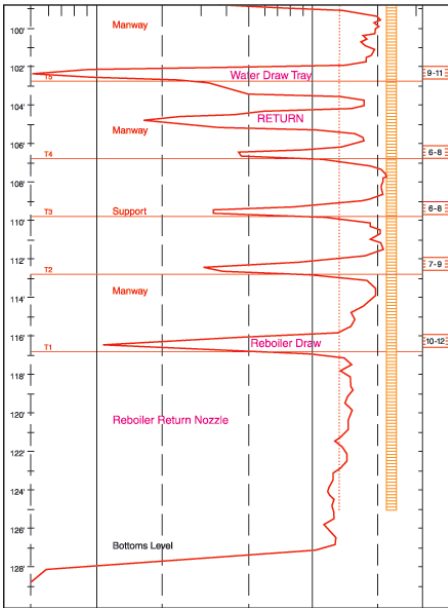

Figure 4 – TRU-SCAN® results confirmed that all trays were in place, and that the liquid level on the total draw Tray 5 was not high enough to allow the liquid to overflow the risers.

water/hydrocarbon interface in the Water Settler. This method was used to determine the difference between the aqueous and hydrocarbon phases. The water/hydrocarbon interface was actually in the boot of the Settler, making it extremely unlikely that water carry-over could account for the water in the bottoms product.

With the most likely possibilities ruled out by the scans, it was suspected that water in the bottoms product was leaking past the chimney tray (Draw Tray 5) through a faulty seal weld or fatigue crack.

Leak Study Verifies Plant Suspicions

The next appropriate step for Tracerco was to conduct a leak study on Draw Tray 5 by injecting a short lived radiotracer into the condensate/distillation feed, and monitor its progression through the column using the detector placements illustrated in Figure 5.

Test results (Figure 6) confirmed a 4.5% leak past the chimney tray into the bottoms product. These test results matched with the results of the previous neutron test and confirmed that water from the settler was not getting back into the column.

Conclusion

As a result of the tests, the problem was precisely identified in a matter of days as opposed to weeks of trial and error. Knowing the cause and severity of the problem well in advance, the Saturates Gas Plant Absorber was shut-down and entered to discover a faulty seal

weld on the leaking draw tray. The tray was repaired and the Absorber was brought back on-line with minimal downtime.

The Best On-line Source For Leak Detection

While scans are used to identify mechanical integrity and process problems within columns, TRACERCO Diagnostic™ Leak studies provide additional techniques to analyze a particular problem on trays and packed beds. In some cases, a TRU-SCAN® may serve to eliminate possibilities instead of providing a single conclusive answer. In some complex problem solving scenarios, it is necessary to run several tests or the same test at different rates to eliminate possibilities. In Case Study 2 scanning the Absorber was the first and most logical step in the troubleshooting process, but a scan by itself was not sufficient to pinpoint the problem. Conversely, if only a leak test had been performed, lingering questions would have remained concerning tray integrity. These questions would have had to be addressed during a shutdown, slowing down repair efforts and extending downtime.

TRACERCO Diagnostic™ Tracer studies are also used to determine the velocity, mean residence time, and plug flow characteristics of a process in addition to determining mass/flow relationships through flare lines or piping systems. If you would like to learn more about our scanning and tracer applications please contact a technical advisor to arrange a onsite presentation or visit our website at www.tracerco.com.

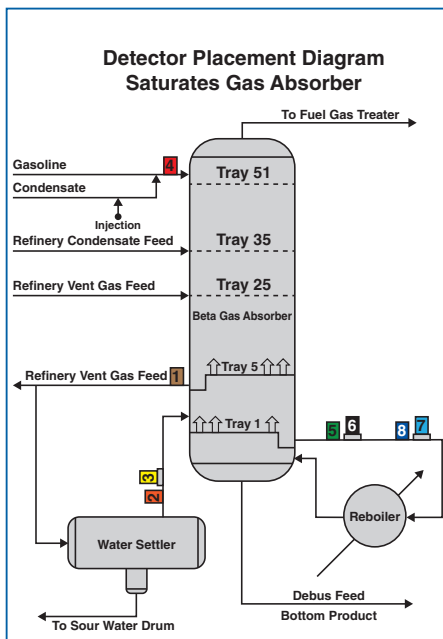

Figure 5 Excessive water in the Absorber bottoms not only limits debutanizer performance, but creates downstream corrosion problems.

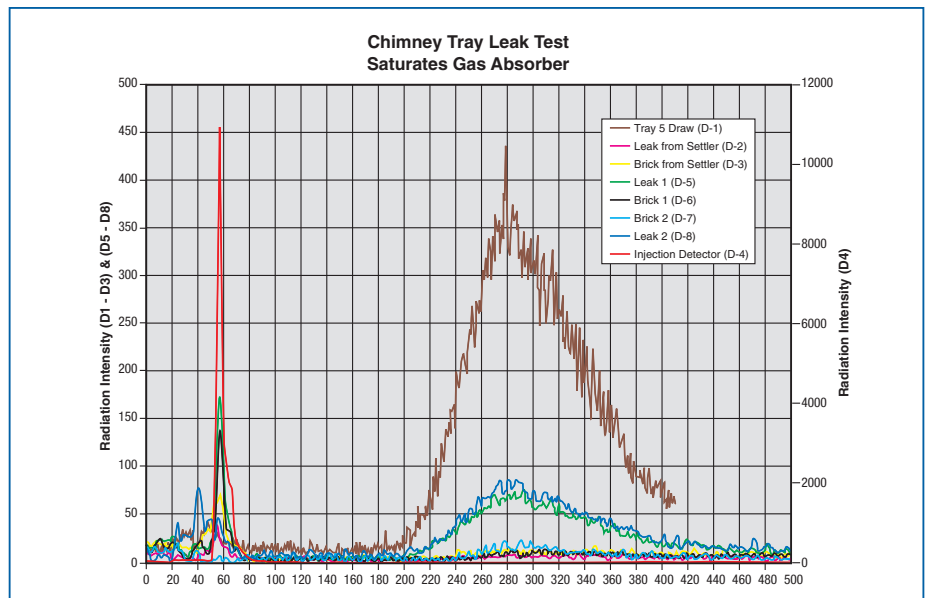

Figure 6 – Radiotracer was injected into the condensate feed to identify the leakage mechanism that was allowing water to progress past the total draw tray. Test results confirmed a 4.5% leak past the chimney tray into the bottoms product.

TRU-SCAN® Field Testing and Process/Hydraulic Analysis Revealed Likely Causes of Flooding Problems in a High Pressure Depropanizer

By Lowell Pless, Tracerco Business Development Mgr – Distillation Applications

TRU-SCAN® and TruTec™ Neutron Backscatter applications provided a clear picture on the root cause of flooding in the transition section of a Depropanizer tower. The Depropanizer tower with a large diameter top section and smaller diameter bottom section was field tested using Tracerco’s TRU-SCAN® and TruTec™ Neutron Backscatter applications and studied to determine the cause of flooding. A two-phase feed entered the tower in the diameter transition zone. TRU-SCANS® identified that the trays in the top section were flooding and liquid accumulation initiated in the transition zone.

The High Pressure (HP) Depropanizer was a replacement tower as part of an expansion of an ethylene plant. On start-up, plant capacity was limited due to the performance of the HP Depropanizer – C4’s in the overhead would go out of specification. In addition, when the plant approached design capacity, sharp increases in HP Depropanizer ΔP was observed.

Based on the process data available it seemed that the top section of trays in the HP Depropanizer were flooding. Rigorous checks of plant operating data versus simulation calculations showed no major deviations from the process design. A TRU-SCAN® was performed to confirm the flooding, as well as to determine where the flooding was originating.

The TRU-SCAN® confirmed that the top section of the HP Depropanizer was flooding. As seen in Figure 7 the flooding started at Tray 28 indicating that the downflow liquid from Tray 28 was restricted at the transition zone. However the initial scan could not provide sufficient information to answer the questions on the root cause of flooding:

- Was the flooding from entrainment or downcomer backup?
- Otherwise, what was restricting the liquid flow?

More scans as well as process and hydraulic analysis were required to understand the

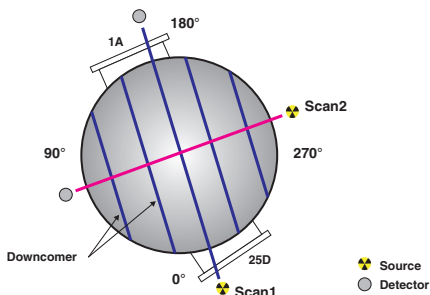

Figure 8 – Scan line orientations

flooding mechanism and the root causes.

TRU-SCAN® Field Tests

To investigate the hydraulic abnormalities in the transition zone, two more TRU-SCANS® were performed, one for active areas and one for downcomers, as shown in Figure 8. Scan 1 was performed across the active area by scanning parallel to the downcomer; Scan 2 was perpendicular through the downcomer.

Figure 9 is an expanded view of the two scans through the transition section. While the orientation of Scan 2 was not the preferred method for investigating the hydraulic condition of Tray 28’s downcomer it did reveal some new information.

Scan 1 showed a level of aerated liquid on Tray 27 while Scan 2 showed Tray 27 operating dry, as seen in Figure 9. Within the highlighted area on Figure 9 Scan 1 (the blue curve) showed a response at Tray 27 signifying

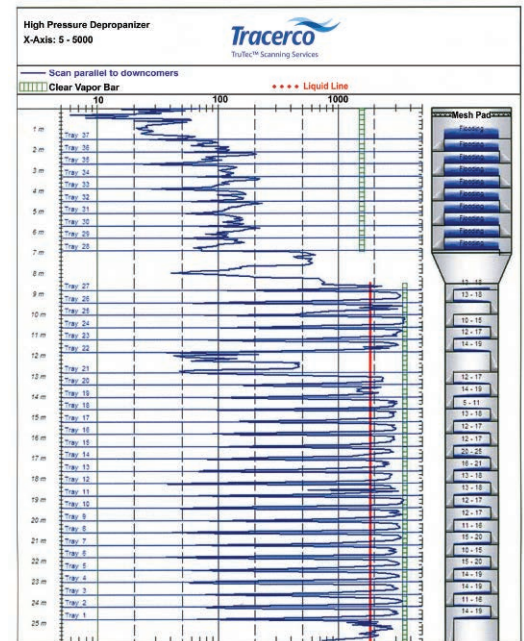

Figure 7 – Initial scan showed that flooding started at Tray 28.

some dense material (liquid) on the active area of Tray 27. Conversely Scan 2 (red curve) within the highlighted area showed nearly no
(continued on page 5)

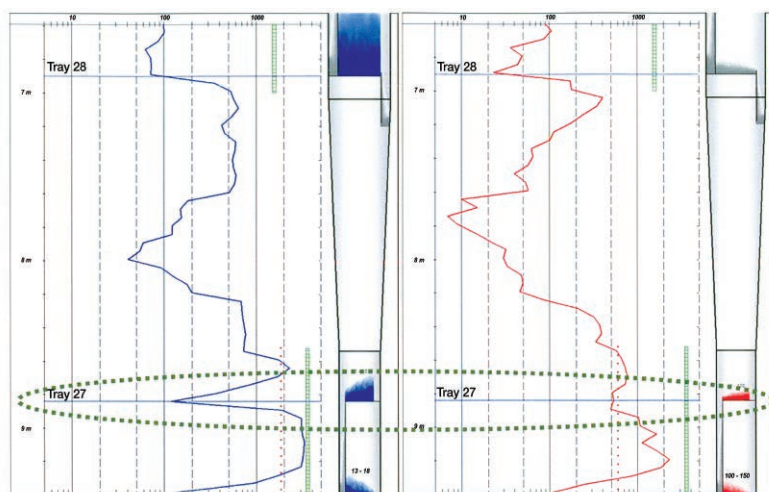

Figure 9 – The liquid holdup or froth on Tray 27 appeared unsteady during the scans

Flooding Problems

(Continued from page 4)

response at Tray 27. There was no dense material i.e., no liquid holding on Tray 27. Since Tray 27 had been seen holding liquid there was no question that Tray 27 was intact mechanically. It was therefore determined to be due to a lack of liquid downflow from Tray 28 above due to a severe restriction. Reconciling this data with plant process information confirmed that as the pressure drop or flooding severity increased and was prolonged, Tray 27 dried up confirming that the downcomer from Tray 28 was indeed restricted.

The scan results and process data made it very clear that there was some form of liquid flow restriction through the downcomer of Tray 28. The question now was, “What was causing the flow restriction? Was there something physical causing the flow restriction or could vapor be bypassing upwards through the downcomer? Evidence indicated that vapor flow was a possibility from the feed up the downcomer from Tray 28. At this point everyone involved, especially plant management required “proof-positive” that the hypothesis of vapor bypass up Tray 28’s downcomer was actually happening.

Verifying the Vapor-Bypassing with TruTec™ Neutron Backscatter Scans

Under most circumstances a TRU-SCAN® through tray downcomers is the recommended approach. However there were some extraordinary reasons why this was not the best approach in the circumstance of this HP Depropanizer. The physical structure of the HP

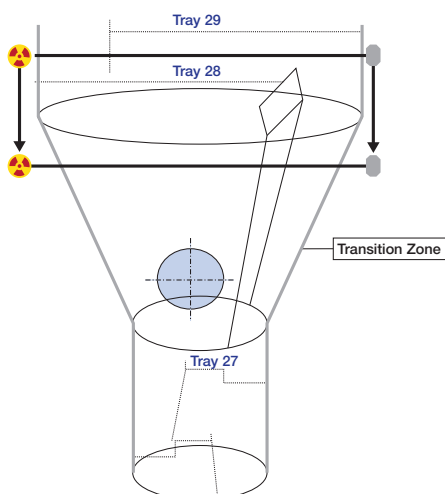

Figure 10 – The transition section imposed challenges to gamma scans

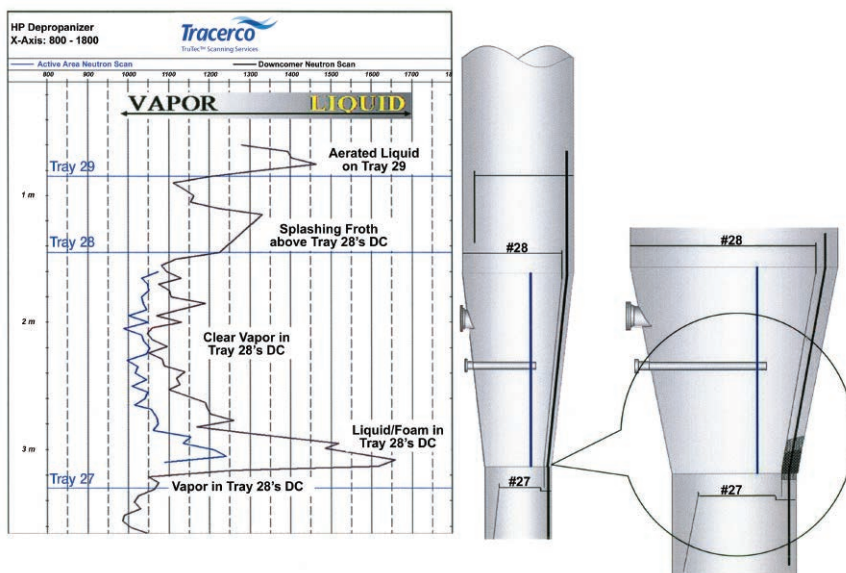

Figure 11 TruTec™ Neutron Backscatter scans of the downcomer in transition section

Depropanizer, top large diameter and bottom smaller diameter, is somewhat challenging for a TRU-SCAN®, as shown in Figure 10. As the gamma source and detector travel down through the transition zone, the source and detector are essentially hanging “in the air”, instead of maintaining contact against the walls. Due to limited access through the transition zone this was unavoidable on this tower. Any slight change in position can affect data gathered.

Additionally the diameter constantly changes through the transition zone. Even if it was possible to maintain the source and detector against the column wall, for each drop in elevation the radiation counts at the detector will vary based on the constantly changing diameter. It could be possible, even if improbable, that a change in internal process density would be negated or exaggerated by the change in diameter or distance from source to detector.

Ideally the best way to carry out a TRU-SCAN® on tray downcomers is to scan parallel to the downcomer walls while the radiation beam passes through the middle of the downcomer. Given the physical features discussed above coupled with the relatively narrow downcomer area, a TRU-SCAN® was not going to provide the kind of detail information desired about the operating condition of the downcomer through the transition zone.

The best approach to scan through the downcomer in the transition zone was to scan with neutrons. Neutrons essentially measure the hydrogen concentration of the material in front of the neutron source/detector apparatus.

In this case a large response was expected where hydrocarbon liquid was present and a smaller response where vapor or less liquid was present.

The TruTec™ Neutron Backscatter scan started above the opening of Tray 28’s downcomer and proceeded down to below the bottom of this downcomer. The black curve in Figure 11 shows the results from this scan. At the bottom of the downcomer where one would expect liquid the neutron response instead showed vapor. There was a “liquid” response further up in the downcomer, several centimeters from the bottom. The reasoning was that this was due to a layer of highly aerated liquid or foam suspended in the downcomer by the vapor. Furthermore, simultaneous neutron readings were taken on the active area of Tray 27 and it was seen to be void of any substantial level of liquid.

Thus the neutron scans validated the hypothesis that vapor was blowing back up the downcomer of Tray 28 and preventing liquid from down-flowing out of the top section, thus flooding the top of the HP Depropanizer.

Solving the Flooding Problem

With a clear picture of the root cause of flooding in the transition section, several steps were proposed and installed to correct the configuration of the HP Depropanizer feed zone.

After the modifications were installed, the HP Depropanizer and the unit were restarted. The unit was able to demonstrate design capacity in a successful plant test run with no further symptoms of flooding.

A Demanding Job Requires an Undemanding Monitor...

The TRACERCO™ PED is an intrinsically safe personal dosimeter you can use anywhere in any environment.

The TRACERCO™ PED is one of the easiest personal radiation dosimeters to read and operate on the market. It is perfect for both radiation specialists that maintain dose records for multiple employees and for workers who are not specifically trained to measure radiation exposure. Everything on the dosimeter has been designed with the user in mind; the display features radiation graph measurement and a simple diagram of a man who fills with color depending on the dose of radiation received. It is intrinsically safe so it can be used in potentially explosive environments. It also comes with a variety

of languages and free DoseVision™ modeling software.

The dosimeter has one of the largest memories on the market, which means it reduces the risk of radiation exposure data being lost or overwritten when the memory gets full. You can choose from 3 radiation measurement modes and four different radiation alarm settings.



The TRACERCO™ Personal Dosimeter does the radiation safety monitoring so you can concentrate on your task.

Radiation Monitor Calibration and Servicing now provided by Tracerco's In-house Team in Pasadena

With full IS health check at no extra cost

In order to provide our valued customers with the comprehensive services they have come to expect from Tracerco, we have now brought our Radiation Monitor Calibration and Servicing in house. That's not all, we are also offering a full IS health check at no extra cost.

We can provide services for the repair, testing and re-calibration of a wide range of gamma dose rate and alpha/beta monitors.

Our service is:

Quick. We offer a three day turn around with an option for an express service.

Flexible. We offer calibration of contamination monitors against a range of isotopes.

Comprehensive. We can test neutron and mud monitors to saturation doses in excess of 10mRem/h.

To learn more about Tracerco's wide range of radiation monitors and calibration services contact a technical advisor to schedule an onsite presentation or visit our website at www.tracerco.com

North American Headquarters:

4106 New West Drive
Pasadena, TX 77507 USA
Tel: 281 291 7769
Fax: 281 291 7709
Toll Free: 800 288 8970

Field Office Locations:

Corpus Christi, TX 78408 USA
Tel: 361 888 8233

Concord, CA 94520 USA

Tel: 925 687 0900

Paramount, CA 90723 USA

Tel: 562 633 8800

Newark, DE 19702 USA

Tel: 302 454 1109

Merrillville, IN 46410 USA

Tel: 219 945 0400

Baton Rouge, LA 70820 USA

Tel: 225 761 0621

Salt Lake City, UT 84119 USA

Tel: 801 478 0736

Edmonton, AB, T6E 6A6 CANADA

Tel: 780 469 0055

Sarnia, ON, N7S 5G5 CANADA

Tel: 519 332 6160

Calgary, AB T2Y 2Z7 CANADA

Tel: 403 931 6705

Rio de Janeiro, RJ, Brazil, CEP 22775-044

Tel: +55 21 3535 7600

XM0544/0/0

If you would like to update our Tracerco Insight distribution list please email your current contact information to tracerco@tracerco.com